

1				2	
NO	QTY	PART NO	DESCRIPTION	STD SEAL KIT	FKM SEAL KIT
1	3	23350084	SPRING, COMP, .240 X .045 X .810 SST		
2	1	39001012	O-RING, (-026), 1.239x.070, 90 AUD	X	39V01012
3	1	39050042	O-RING, (-011), .301x.070, 90 AUD	X	39051025
4	1	39050062	O-RING, (-020), .864x.070, 70 AUD	X	39V50033
5	1	39054033	BU RING, (-020), PFTE, CUT	X	X
6	1	81571004	PISTON, PIN, PWR, 600		
7	1	81571005	CUP, PISTON, PIN, PWR, 600		
8	1	81571006	RETAINER, PIN, PWR, 600		
9	1	81571007	RETAINER, MNTG, PIN, PWR, 600		
10	1	91571000	ASSY, PIVOT & CAP, 600		
N/A	N/A	60157100	KIT, SEAL, PIN, PWR, 600	NOTED	N/A
N/A	N/A	6V157100	KIT, SEAL, PIN, PWR, 600, FKM	N/A	NOTED

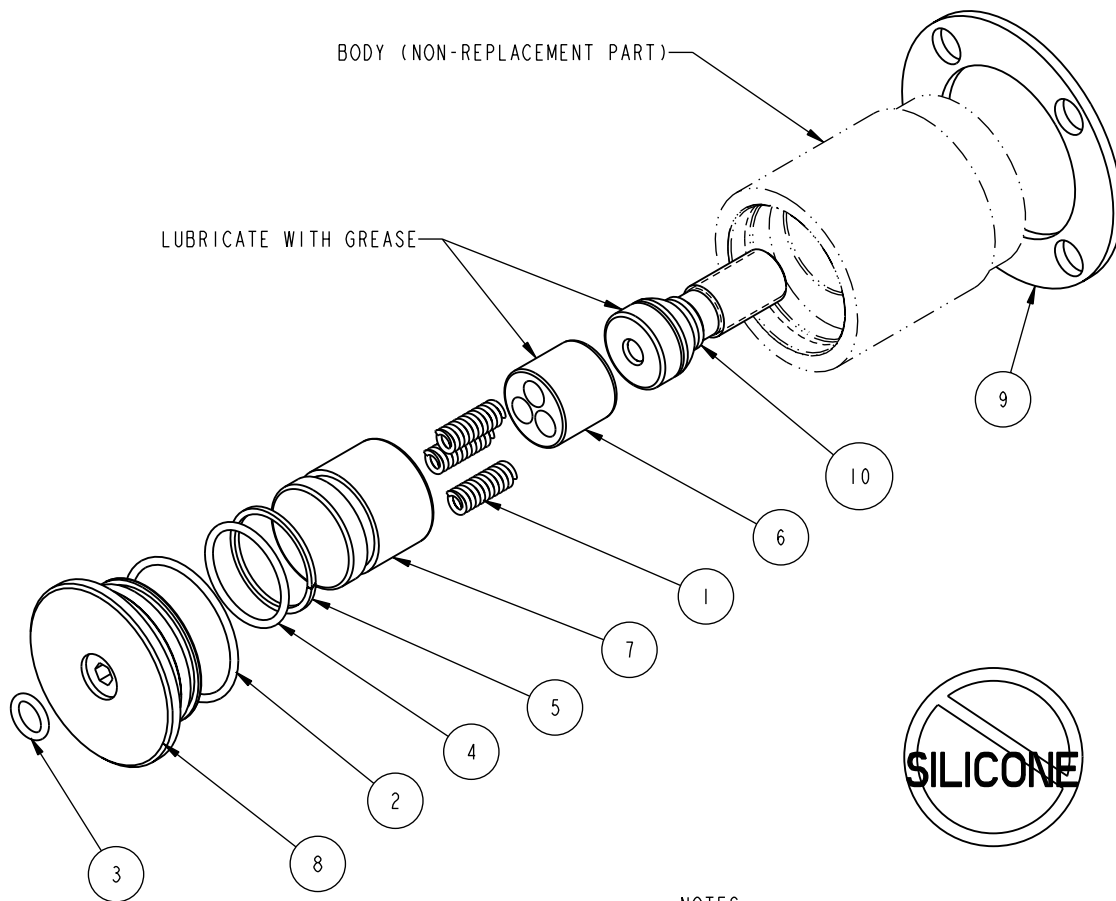

TORQUE TO  
13 IN-LBS

- NOTES:  
 1. APPLY LUBRICANT TO ALL SEALS PRIOR TO ASSEMBLY.  
 2. DO NOT USE SILICONE TYPE LUBRICANTS.

### PARTS LIST



VEKTEK, INC.  
 1334 E. SIXTH AVE. P.O. BOX 625  
 EMPORIA, KS. 66801 U.S.A.

ASSEMBLIES AFFECTED  
 15-7110-00

PARTS LIST, PIN, PWR, 600

A	2442	RELEASE	K. ROEMER	12/11/12
REV	IN ACCORDANCE WITH ECN	EFFECTIVE DATE	REVISED BY	DATE
DRW BY:	K. ROEMER	DRAWING STATUS: <b>Released</b>		
DATE:	08/20/12	PRODUCTION APPROVED FOR RELEASED STATUS ONLY		

SIZE  
 A PL15100

REV  
 A

FORM FEG035\_PL\_AS1ZE, REV. A

SHEET 1 OF 1